

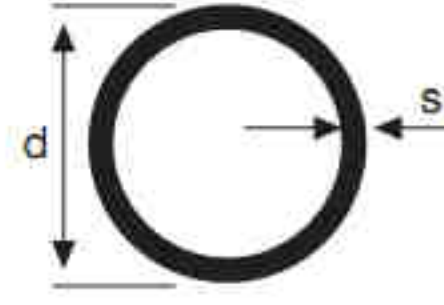

SİSTEM®

Alüminyum San. ve Tic. A.Ş.



YUVARLAK BORULAR

PROFİL NO.	d/mm	s/mm	kg/m
3493	8	2	0,102
995	10	1	0,076
1482	10	1,6	0,113
3860	10	2	0,136
2062	11	1	0,085
1237	12	1	0,093
1568	12	1,5	0,133
1586	12	2	0,170
729	12,7	2,35	0,207
1228	13	1	0,103
668	13	2	0,186
579	14	1	0,110
876	14	2	0,203
2732	15	1	0,119
1130	15	1,5	0,172
2733	15	2	0,222
1078	16	1	0,127
4983	16	1,5	0,185
4234	16	2	0,238
510	16	2,5	0,286
3767	16	3	0,331
5061	16	4	0,408
2209	16	5	0,467
2734	18	1	0,145
4791	18	1,5	0,210
2120	18	2,7	0,351
586	19	1	0,153
2638	19	2,5	0,350
792	20	1	0,162
1246	20	2	0,305
4333	20	2,5	0,371
563	22	1	0,178
2027	22	1,5	0,262
2028	22	2	0,340
1500	22	5	0,721
2103	23,8	4,9	0,786
2061	24	5	0,806
2784	24,8	1,75	0,343
1299	24,9	8,9	1,207
562	25	1	0,203
558	25	1,5	0,300
2009	25	2	0,390
1322	25	2,5	0,478
908	25	3	0,559
4880	25	5	0,849
695	25,4	2,7	0,520
1454	25,7	1,2	0,248
561	28	1	0,229
4057	28	2	0,441
1585	28	3	0,637
587	29,5	2,25	0,520
1096	30	1	0,246
1095	30	2	0,475
1089	30	2,4	0,562
624	30	2,5	0,583
517	30	3	0,686
1913	30	3,5	0,786
2576	30	3,95	0,872
2575	30	4	0,883
639	30	5	1,061
3082	30	10	1,696
3083	30	12,5	1,855

PROFİL NO.	d/mm	s/mm	kg/m
1300	31,8	11,6	1,987
1581	32	1	0,262
1179	32	1,5	0,389
4923	32	2	0,511
1459	32	2,5	0,626
2191	35	1	0,289
4021	35	1,2	0,344
4157	35	2	0,560
1233	35	2,5	0,689
3857	35	3	0,814
809	35	7,5	1,750
4350	35	14,4	2,516
5244	35,5	14,5	2,584
1861	36	1	0,297
1156	36	1,5	0,439
1770	36	6	1,527
6023	38	4	1,154
750	40	1,25	0,410
3694	40	2	0,644
3862	40	3	0,942
6024	40	5	1,485
4338	40	10	2,545
3081	40	15	3,181
5246	40,5	16,1	3,343
3978	42	3	0,992
3368	44,5	12,25	3,351
5666	45	2	0,730
5293	45	3	1,069
5710	46	1,5	0,567
5700	46	5	1,739
1783	46	9	2,824
2366	48	2	0,780
4067	48	3	1,145
2221	50	1,2	0,497
2395	50	1,5	0,617
4982	50	1,8	0,737
1129	50	2	0,814
5083	50	2,3	0,932
2517	50	2,5	1,007
2574	50	3	1,196
588	50	4	1,560
715	50	5	1,909
1784	50	9	3,129
3849	50	10	3,393
751	60	2	0,983
2758	60	2,5	1,219
3851	60	3	1,450
3852	60	5	2,332
4250	60	10	4,242
3828	60	15	5,725
5040	60	20	6,786
4711	63	8	3,733
3974	65	2,5	1,325
3853	70	2,5	1,431
827	70	3	1,705
3848	70	15	6,998
780	74,5	2	1,230
1763	75	5,5	3,243
4235	76	3	1,858
3695	80	2	1,323
3854	80	2,5	1,643
5145	80	3	1,960



SİSTEM®

Alüminyum San. ve Tic. A.Ş.

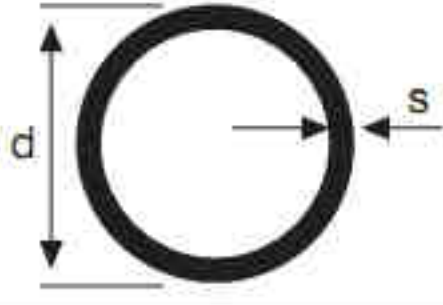

YUVARLAK BORULAR

PROFİL NO.	d/mm	s/mm	kg/m
5117	80	5	3,181
779	81,5	2,5	1,675
1367	81,5	4	2,630
581	85	5	3,392
1439	85	5	3,394
4090	90	3	2,214
3861	90	15	9,542
625	95	2,5	1,962
4998	100	3	2,469
4999	120	5	4,878
2673	120	7,5	7,158
2520	125	2,5	2,599
4349	130	42,5	31,544
2672	145	5	5,937
2519	150	2,2	2,758
5690	168	8	10,858
3097	15,5	1,8	0,209
3171	15,9	2	0,236
3859	18,3	1	0,146
5554	18,85	1,3	0,195
4655	25	2,5	0,478
5535	40	2,5	0,797
5548	41	10,45	2,708
5569	54,3	2	0,888
3884	54,5	2	0,891
3708	58	1,3	0,625
3709	63	1,5	0,782
4666	125	6	6,056
3959	140	2,3	2,686
4348	151	53	43,419
3960	170	2,5	3,552

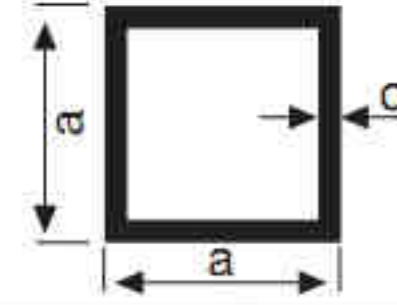

KARE PROFİLLER

PROFİL NO.	a/mm	c/mm	kg/m
1027	12	1	0,119
951	14	1	0,140
4541	15	1,5	0,219
511	20	1	0,205
606	20	1,5	0,300
1388	20	2	0,389
1432	20	2,5	0,473
742	25	1,3	0,332
1838	25	2	0,497
2816	25	3	0,713
3588	30	1	0,313
853	30	1,2	0,372
3812	30	2	0,605
3813	30	3	0,875
2817	30	4	1,123
4015	34	2	0,691
1644	35	1,1	0,402
5660	35	2	0,713
1317	40	1	0,421
589	40	1,2	0,502
5330	40	1,3	0,544
5994	40	1,5	0,624
1059	40	2	0,820
4810	40	2,5	1,013
3815	40	3	1,199
3699	40	4	1,555
806	50	2	1,036
1044	50	3	1,522
4241	50	4	1,987
5255	50	5	2,430
1910	59	2	1,231
6136	60	1,5	0,948
4243	60	2	1,253
4231	60	3	1,847
3817	60	4	2,419
3283	70	4	2,851
3981	80	2	1,685
5701	80	2,5	2,093
3834	80	3	2,495
3697	80	4	3,283
5116	80	5	4,050
5977	90	4	3,715
4059	100	3	3,143
3696	100	4	4,147
4014	100	5	5,130
3823	120	5	6,210
4760	8	1,2	0,087
1909	15	1	0,146
3119	23,4	1,1	0,265
3488	25	1,8	0,442

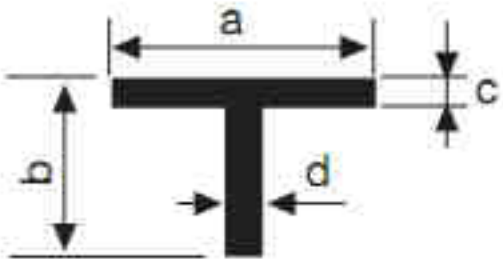

T PROFİLLERİ

PROFİL NO.	a/mm	b/mm	c/mm	d/mm	kg/m
939	10	10	1,3	1,3	0,065
1850	10,6	43	1,5	1,5	0,211
1104	13,5	15	1,5	1,5	0,109
1238	15	35	1,5	1,5	0,197
664	20	20	1,2	1,2	0,124
1060	20	20	1,8	1,8	0,186
892	25	25	1,2	1,2	0,157
1264	25	25	1,5	1,5	0,197
1043	30	30	1,3	1,3	0,205
1269	30	30	1,5	1,5	0,238
605	30	30	2	2	0,313
959	30	35	2	2	0,340
1180	35	18	3	3	0,405
551	40	40	4	4	0,820
4668	50	17	3	7	0,359
5147	50	50	5	5	1,283
2714	60	42,5	2,5	2,5	0,675
5417	60	60	6	6	1,847
2823	60	95	8	8	3,175
5470	75	14,5	2,5	7	0,733
5551	90	10	4,5	10,8	1,254
5560	140	10	4,5	10,8	1,862
5426	60	80	6	6	2,171

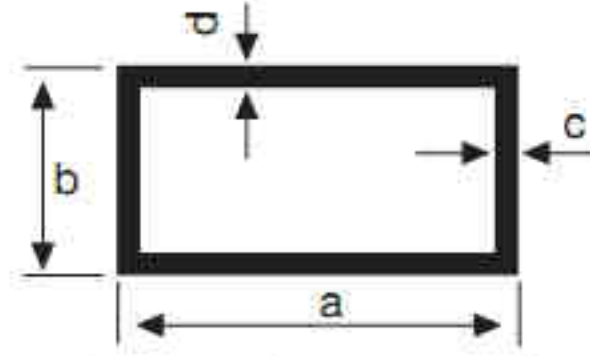

DİKDÖRTGEN PROFİLLER

PROFİL NO.	a/mm	b/mm	c/mm	d/mm	kg/m
1114	16	12	1	1	0,140
955	18	12	1	1	0,151
741	18	12	1,5	1,5	0,219
1037	18	14	1	1	0,162
5993	20	8	1,2	1,2	0,166
761	20	10	1,2	1,2	0,165
4545	25	15	2	2	0,389
943	25	17	1	1	0,216
541	27,5	13,5	1,2	1,2	0,256
1819	30	15	1	1	0,232
1112	30	15	2	2	0,443
733	30	20	1,2	1,2	0,308
5323	30	20	2	2	0,497
821	35	8	1,3	1,3	0,284
1092	40	15	1,5	1,5	0,421
3489	40	15	1,8	1,8	0,500
4665	40	20	1	1	0,313
852	40	20	1,2	1,2	0,373
5331	40	20	1,3	1,3	0,404
3814	40	20	2	2	0,604
5005	40	20	2,5	2,5	0,743
4239	40	20	3	3	0,875
621	40	25	1	1	0,340
5369	40	25	2	2	0,659
2677	40	30	1	1	0,367
4397	40	30	2	2	0,712
4944	40	30	2,5	2,5	0,878
6251	40	30	3	3	1,037
4952	40	35	2	2	0,767
3816	50	20	2	2	0,712
1782	50	25	2	2	0,767
1085	50	30	1,5	1,5	0,624
3980	50	30	2	2	0,820
4917	50	30	2,5	2,5	1,013
3855	50	30	3	3	1,199
4792	50	30	4	4	1,555
1318	50	40	1	1	0,475
797	50	40	1,1	1,1	0,521
3870	50	40	2	2	0,928
4547	50	40	2,5	2,5	1,148
3827	50	40	3	3	1,360
767	60	20	1,5	1,5	0,624
4240	60	20	2	2	0,821
516	60	30	1,4	1,4	0,659
4489	60	30	2	2	0,929
5259	60	30	3	3	1,361
1079	60	40	1,5	1,5	0,786
3821	60	40	2	2	1,036
4056	60	40	2,5	2,5	1,282
3822	60	40	3	3	1,522
4407	60	40	4	4	1,987
4236	60	50	3	3	1,685
5832	60,5	20,4	1,7	1,7	0,712
1652	67	26	1	1	0,491
5462	70	20	2	2	0,929
1121	70	30	1,5	1,5	0,786
6252	70	30	3	3	1,523
5370	70	50	4	4	2,419
1125	72	40	2	2	1,166
746	75	32	1,3	1,3	0,733

PROFİL NO.	a/mm	b/mm	c/mm	d/mm	kg/m
4946	80	20	1,5	1,5	0,291
4055	80	20	2	2	1,036
5903	80	30	2	2	1,145
6137	80	40	1,5	1,5	0,948
4058	80	40	2,5	2,5	1,552
4546	80	40	3	3	1,847
4371	80	40	4	4	2,419
4066	80	40	6	6	3,500
4945	80	50	3	3	2,009
4238	80	50	4	4	2,635
3982	80	60	3	3	2,170
3698	80	60	4	4	2,851
1143	95	30	1,5	1,5	0,988
1248	95	50	1,5	1,5	1,150
5505	100	18	2	2	1,231
4918	100	20	2	2	1,253
6250	100	20	3	3	1,847
4811	100	40	2,5	2,5	1,823
4001	100	50	2,5	2,5	1,957
4237	100	50	3	3	2,333
4158	100	50	4	4	3,067
5435	100	50	5	5	3,780
4881	100	60	3	3	2,495
5294	100	60	4	4	3,283
4401	120	60	4	4	3,715
3111	130	60	4	4	3,931
6260	140	80	4	4	4,580
5168	150	50	4	4	4,147
4233	150	100	3	3	3,953
3434	155	80	3	3	3,709
3007	23,5	7,8	1	1	0,158
2825	30	20	2	2	0,496
3003	35	20	2	2	0,551
2958	40	10	2	2	0,498
5329	40	14	1,5	1,5	0,413
5610	40	16	2,5	2,4	0,670
4558	70	20	2	2	0,929
5197	150	50	3,5	3,5	3,648

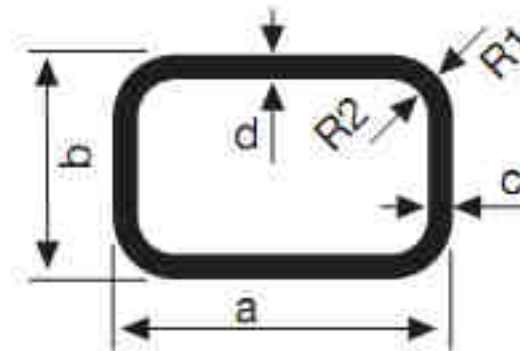

RADİUSLU DİKDÖRTGEN BORULAR

PROFİL NO.	a mm	b mm	c mm	d mm	R1 mm	R2 mm	kg/m
590	30	20	1,3	1,3	2	0,7	0,333
933	61	27	3,3	3,3	-	2,7	1,456
1496	26	22	1,1	1,1	1	1	0,260
1719	15	15	1,5	1,5	-	-	0,235
1909	15	15	1	1	-	-	0,148
2041	23,4	23,4	3	3	-	-	0,640



SİSTEM®

Alüminyum San. ve Tic. A.Ş.

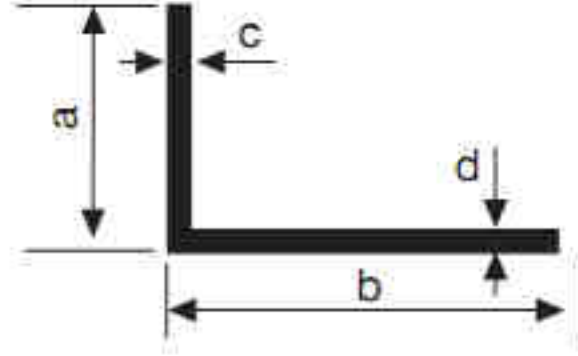

L PROFİLLERİ

PROFİL NO.	a/mm	b/mm	c/mm	d/mm	kg/m
529	15	10	1,2	1,2	0,077
769	20	10	1,2	1,2	0,092
960	20	10	2	2	0,151
2166	20	12	1,2	1,2	0,100
4638	20	15	2	2	0,178
914	25	10	1,2	1,2	0,108
676	25	10	1,5	1,5	0,135
3793	25	10	2	2	0,178
4466	25	15	2	2	0,205
846	25	15	2,5	2,5	0,254
993	25	15	3,2	3,2	0,319
705	25	17	3,2	2,7	0,305
770	25	20	1,3	1,3	0,154
708	29	10,5	1,2	1,2	0,124
1265	30	10	1,2	1,2	0,125
593	30	10	1,5	1,5	0,157
637	30	15	1,2	1,2	0,142
1131	30	15	1,5	1,5	0,175
4098	30	15	2	2	0,232
4045	30	15	3	3	0,340
3700	30	20	2	2	0,259
4088	30	20	3	3	0,380
4778	35	20	2	2	0,286
4096	35	25	2	2	0,313
4924	40	10	2	2	0,259
1106	40	10	3	3	0,381
4273	40	15	2	2	0,286
4883	40	20	1,2	1,2	0,192
805	40	20	1,5	1,5	0,237
545	40	20	2	2	0,313
5303	40	20	3	3	0,462
4925	40	20	4	4	0,605
4715	40	25	2	2	0,340
4539	40	30	2	2	0,367
4776	40	30	3	3	0,543
3487	45	30	2,8	2,8	0,546
720	50	17	1,5	1,5	0,265
2042	50	18	4	2,5	0,505
3914	50	20	1,3	1,3	0,241
2779	50	20	1,5	1,5	0,277
3701	50	20	2	2	0,367
4142	50	25	5	5	0,945
3911	50	30	2	2	0,421
4922	50	30	2,5	2,5	0,524
3702	50	30	5	5	1,012
1049	60	20	1,2	1,2	0,255
4540	60	20	2	2	0,421
5665	60	25	2	2	0,448
4143	60	25	5	5	1,080
4089	60	30	2	2	0,475
3820	60	40	2	2	0,529
5304	60	40	3	3	0,786
3792	60	40	4	4	1,037
4156	60	40	5	5	1,283
3962	60	45	2,3	2,3	0,637
2666	65	30	1,8	1,8	0,454
3846	70	20	2	2	0,475
4106	70	20	2,5	2,5	0,590
4410	70	30	2	2	0,529

PROFİL NO.	a/mm	b/mm	c/mm	d/mm	kg/m
5237	70	60	12	12	3,823
3915	80	20	1,5	1,5	0,399
1991	80	30	1,3	1,3	0,381
3832	80	30	3	3	0,867
4536	80	40	2	2	0,637
4537	80	40	4	4	1,253
6259	80	50	4	4	1,361
3704	100	50	3	3	1,191
5702	100	60	8	8	3,283
4690	100	70	2	2	1,793
5732	120	40	2	2	0,853
4538	120	40	3	3	1,272
3705	120	80	10	10	5,130
2932	150	90	5	5	3,172
3706	200	100	10	10	7,83
907	15	5	2	2	0,095
986	25	15	1,9	1,9	0,195
3661	30	10	2	2	0,205
1801	33	5,5	2	2	0,197
2853	40	20	3	3	0,462
3659	45	20	2	2	0,340
5613	50	11	3	3	0,470
2857	50	30	3	3	0,623
3002	50	35	4	4	0,875
2667	55	25	1	1	0,213
3662	60	25	2,5	2,5	0,557
2902	75	45	2	2	0,637
2925	80	40	6	6	1,847
5436	95	44	4	4	1,458
2858	100	60	10	10	4,050
2918	104	44	4	4	1,555
5437	104	44	4	4	1,555

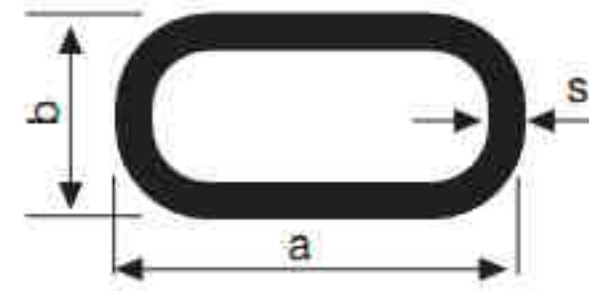

YASSI BORULAR

PROFİL NO.	a/mm	b/mm	s/mm	kg/m
583	26	15	1,5	0,262
709	26	10	1,5	0,238
749	80	26	1,5	0,752
1200	50	20	1,5	0,482
6027	29,9	12,2	1,3	0,246

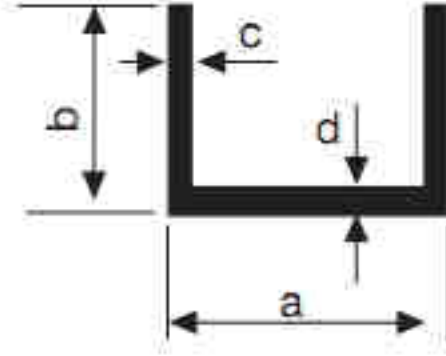

U PROFİLLERİ

PROFİL NO.	a/mm	b/mm	c/mm	d/mm	kg/m
931	7,8	27	1,4	3,2	0,249
743	7,9	9,9	1,4	1,4	0,095
6071	8	8	1	1	0,060
713	9,6	11	1,2	1,2	0,095
6072	10	10	1	1	0,076
6138	10	15	1,2	1,2	0,122
883	10	15	2	2	0,195
6073	11	12	1,5	1,5	0,130
4099	12	12	2	2	0,173
4799	12	15	2	2	0,205
1820	12	18	1,3	1,3	0,160
714	12	18	1,5	1,5	0,181
2032	14	28	1,2	1,2	0,218
1524	14,8	30	2,5	2,5	0,471
1086	15	15	1,1	1,1	0,127
3296	15	15	1,5	1,5	0,170
3444	15	15	2	2	0,222
6076	15	20	1,5	1,5	0,211
985	15	20	1,9	1,9	0,262
6077	17	20	1,5	1,5	0,219
949	17,5	16	1,1	1,1	0,140
646	19	20	1,1	1,1	0,168
6074	20	10	2	2	0,195
5585	20	13	1,1	1,1	0,130
6075	20	15	2	2	0,249
1068	20	20	1,5	1,5	0,230
4548	20	20	2	2	0,302
3445	20	20	2	2	0,302
5149	20	30	2	2	0,411
5792	20	40	2	2	0,519
3657	20	40	2,5	2,5	0,641
4428	20,4	9	1	1	0,097
1571	21	25	1,2	1,2	0,221
6070	21	50	2,5	2,5	0,783
3379	23	23	1,5	1,5	0,267
3158	25	15	2	2	0,275
752	25	17	1,1	1,1	0,168
4272	25	25	2	2	0,383
1525	29,6	30	2,5	2,5	0,571
4744	30	20	2	2	0,357
4242	30	30	2	2	0,464
3004	35	35	3	3	0,802
4406	40	20	2	2	0,410
4814	40	20	4	4	0,777
2869	40	30	2	2	0,518
6078	40	40	2	2	0,627
3835	40	40	3	3	0,923
3824	40	40	4	4	1,209
6286	50	40	4	4	1,318
3825	50	50	4	4	1,533
5381	60	40	2,5	2,5	0,911
5522	85,5	16,2	1,2	1,2	0,375
2752	86	40	2	2	0,875
1572	90	20	2	2	0,680

PROFİL NO.	a/mm	b/mm	c/mm	d/mm	kg/m
5703	91	45	5	5	2,309
884	100	8	2	2	0,605
5169	100	50	5	5	3,240
2554	120	30	2	2	0,950
2926	125	80	8	8	5,810
2927	150	60	5	5	3,510
2928	150	65	8	8	5,702
5152	160	80	8	8	6,566
5241	176	15	2	2	1,091
5242	186	15	2	2	1,145
3357	19	20	1,1	1,1	0,167
3292	13	20	1,1	1,1	0,150
885	20	30	2	2	0,405
5422	22	10	1,5	1,5	0,158
5362	29	50	3	5	1,121
3207	39,2	41,6	2	2	0,640
5327	44	25	1,3	1,3	0,321
4748	53,7	37,9	3	3	1,000
3009	60	80	3	3	1,733
5319	70	30	4,5	6	1,717

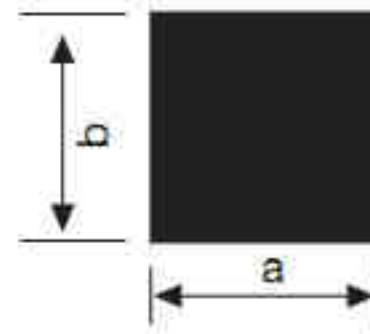

KARE ÇUBUKLAR

PROFİL NO.	a/mm	b/mm	kg/m
5170	10	10	0,270
4095	12	12	0,389
4504	14	14	0,529
1862	15	15	0,608
4022	18	18	0,874
1034	20	20	1,080
1161	25	25	1,687
4091	30	30	2,430
3316	35	35	3,307
4092	40	40	4,320
4641	50	50	6,750
4642	55	55	8,168
4643	60	60	9,720
4644	65	65	11,408
4645	70	70	13,230
4646	75	75	15,188
2528	80	80	17,280
2296	8	8	0,173



SİSTEM®

Alüminyum San. ve Tic. A.Ş.

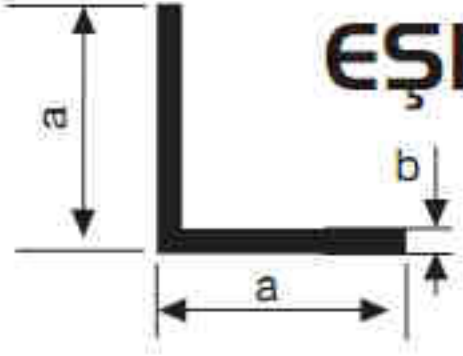

EŞKENAR KÖŞEBENT PROFİLLER

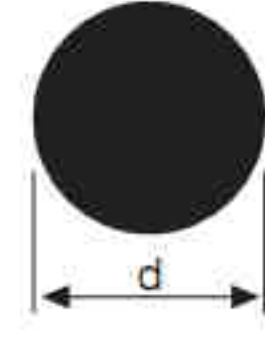

YUVARLAK ÇUBUKLAR

PROFİL NO.	a/mm	c/mm	kg/m
6068	10	1	0,052
1030	10	1,2	0,061
4637	10	2	0,097
530	15	1,2	0,093
6069	15	1,5	0,116
4367	15	2	0,151
4830	15	3	0,219
552	20	1,2	0,124
636	20	1,5	0,157
617	20	2	0,205
4087	20	3	0,300
543	25	1,2	0,158
518	25	1,5	0,196
3378	25	2	0,259
706	25	2,7	0,346
997	25	3,2	0,405
544	30	1,2	0,189
634	30	1,5	0,238
604	30	2	0,313
609	30	3	0,462
3977	30	5	0,742
2313	30	5	0,742
635	40	1,5	0,319
719	40	2	0,421
2204	40	2,5	0,524
513	40	3	0,624
608	40	4	0,821
3818	40	5	1,012
3961	45	2,3	0,545
773	50	2	0,529
3703	50	3	0,785
3819	50	4	1,037
577	50	5	1,282
5696	60	2	0,637
5322	60	3	0,948
4155	60	4	1,253
1135	60	5	1,553
2355	60	6	1,847
4105	70	2,5	0,929
1144	70	5,8	2,100
1145	80	3	1,272
2553	80	5	2,092
2924	80	8	3,283
5167	100	4	2,117
5146	100	10	5,130
2851	40	4	0,821
2850	45	6	1,358

PROFİL NO.	d/mm	kg/m
1066	10	0,212
2631	11,7	0,290
804	12	0,311
6253	14	0,416
5143	15	0,478
1019	16	0,543
3722	17	0,612
4511	18	0,685
549	20	0,847
672	22	1,026
538	25	1,323
2521	25,5	1,380
3720	26	1,433
4542	28	1,663
539	30	1,908
4612	32	2,171
523	35	2,597
4543	36	2,749
4639	38	3,062
525	40	3,391
4507	41	3,564
3972	42	3,740
2138	44	4,107
524	45	4,293
1097	50	5,300
4509	51	5,516
718	52	5,735
832	55	6,415
4865	56	6,650
614	60	7,633
4508	61	7,889
4654	62	8,151
4544	63	8,416
671	65	8,959
1103	70	10,390
4510	71	10,689
833	75	11,929
4710	76	12,249
1076	80	13,573
4785	82	14,259
834	85	15,322
4640	90	17,177



SİSTEM®

Alüminyum San. ve Tic. A.Ş.

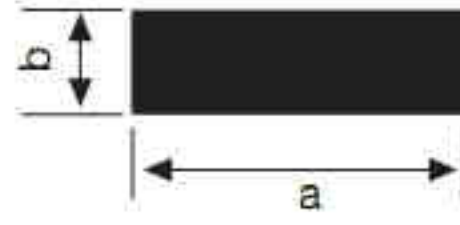

LAMA PROFİLLER

PROFİL NO.	a/mm	b/mm	kg/m
1397	6,5	3,5	0,062
1295	8,7	2,9	0,068
977	10	1,5	0,041
1818	12	1,5	0,049
653	12	4	0,130
2291	15	2,5	0,101
2055	15	5	0,203
2002	15	10	0,405
4777	15	8	0,324
1250	15,1	3	0,122
2580	16	7	0,302
2108	16,1	11	0,478
3847	20	2	0,108
506	20	3	0,162
647	20	4	0,216
503	20	5	0,270
1072	20	6	0,324
519	20	8	0,432
555	20	10	0,540
4989	20,1	3,1	0,169
2086	21	14	0,794
994	21,3	5,3	0,305
704	21,5	5,5	0,319
818	25	3	0,202
638	25	4	0,270
4054	25	5	0,338
723	25	6	0,405
4889	25	10	0,675
1234	25	15	1,012
1165	25	20	1,350
3717	26	7	0,491
3648	26,3	6	0,426
3658	30	2	0,162
505	30	3	0,243
1075	30	4	0,324
710	30	5	0,405
4812	30	6	0,486
4505	30	7	0,567
4405	30	8	0,648
1202	30	10	0,810
5144	30	15	1,215
1469	30	16	1,296
1162	30	20	1,620
1164	30	25	2,025
2610	35	5	0,472
4793	35	6	0,567
2573	35	17	1,606
1253	36	2,9	0,282
849	37	1,5	0,150
896	40	2	0,216
508	40	3	0,324
848	40	4	0,432
507	40	5	0,540
4232	40	6	0,648
4182	40	8	0,864
860	40	10	1,080
1163	40	15	1,620
4065	40	20	2,160
3975	40	25	2,700
3660	50	2	0,270
575	50	3	0,405
5101	50	4	0,540
509	50	5	0,675

PROFİL NO.	a/mm	b/mm	kg/m
2818	50	8	1,080
1069	50	10	1,350
4061	50	15	2,025
4081	50	20	2,700
4082	50	25	3,375
4083	50	30	4,050
4084	50	35	4,725
3976	50	40	5,400
1081	60	3	0,486
3973	60	4	0,648
4085	60	5	0,810
3863	60	8	1,296
1065	60	10	1,620
5418	60	12	1,944
4086	60	15	2,430
4613	60	20	3,240
3850	60	25	4,050
4786	60	30	4,860
4968	65	30	5,265
716	70	3	0,567
4369	70	10	1,890
4614	70	20	3,780
3831	70	35	6,615
3864	70	40	7,560
4062	80	5	1,080
4967	80	6	1,296
591	80	8	1,728
1051	80	10	2,160
4737	80	15	3,240
3979	80	20	4,320
4609	80	50	10,800
4610	80	60	12,960
3943	90	15	3,645
4611	90	30	7,290
717	100	2	0,540
1245	100	3	0,810
612	100	5	1,350
5716	100	6	1,620
3692	100	8	2,160
1054	100	10	2,700
748	100	15	4,050
3693	100	20	5,400
1502	110	3	0,891
4409	110	8	2,376
3298	110	20	5,940
2526	120	10	3,240
2684	120	10	3,240
4738	120	15	4,860
4370	120	20	6,480
3232	127	3	1,029
5715	150	6	2,430
2522	150	10	4,050
2523	150	15	6,075
4787	150	30	12,150
4739	160	10	4,320
4740	180	10	4,860
4741	200	10	5,400
4368	200	15	8,100
3529	200	25	13,500
3650	8,9	7	0,168
3113	10	3	0,081
3649	17	4,5	0,204
3049	25	8	0,543
2959	31,5	4	0,340
2842	35,1	8	0,759
3214	40	30	3,238



SİSTEM®

Alüminyum San. ve Tic. A.Ş.

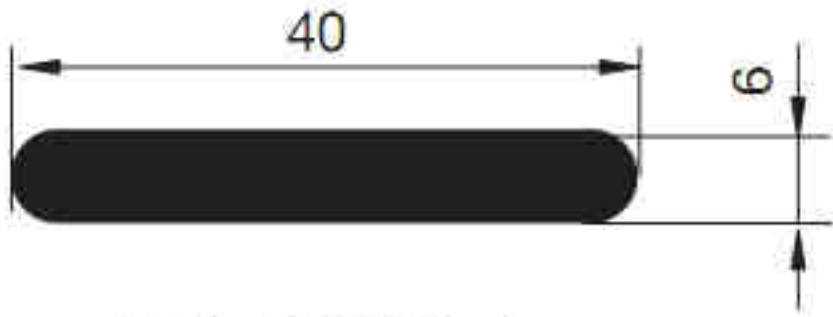

504 - 0.645 Kg/m

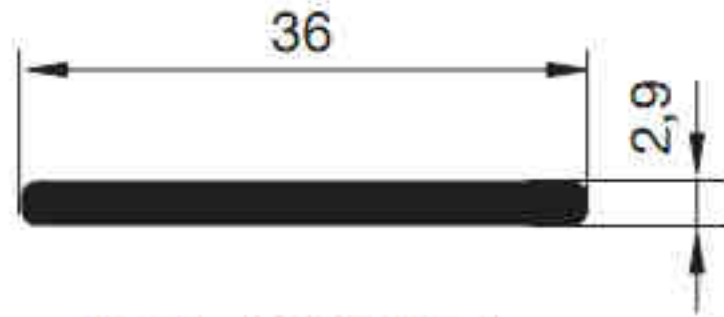

1253 - 0.283 Kg/m

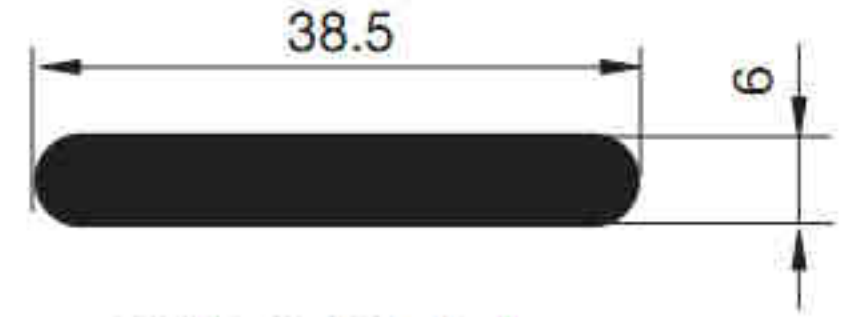

810 - 0.621 Kg/m

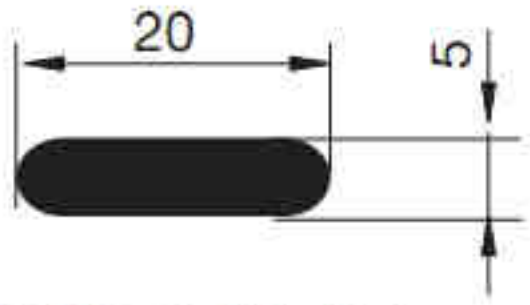

1313 - 0.257 Kg/m

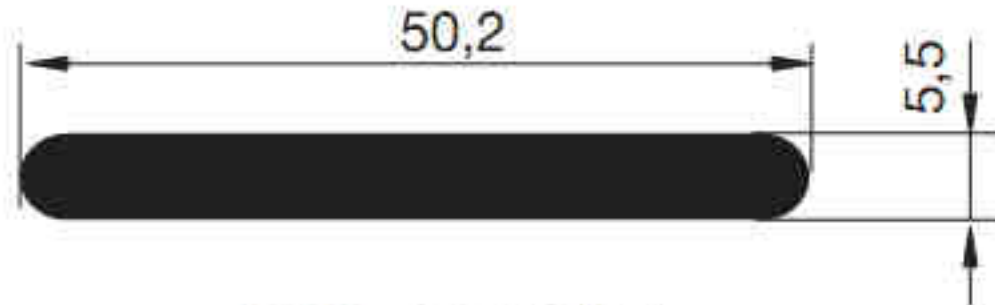

1137 - 0.730 Kg/m

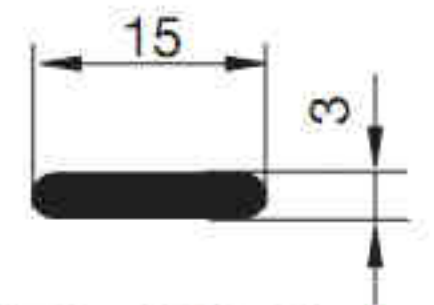

877 - 0.122 Kg/m

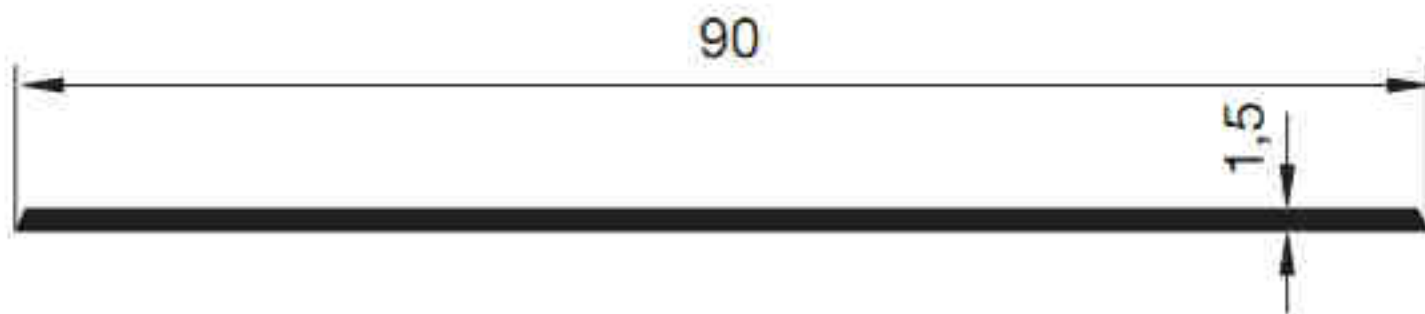

1282 - 0.362 Kg/m

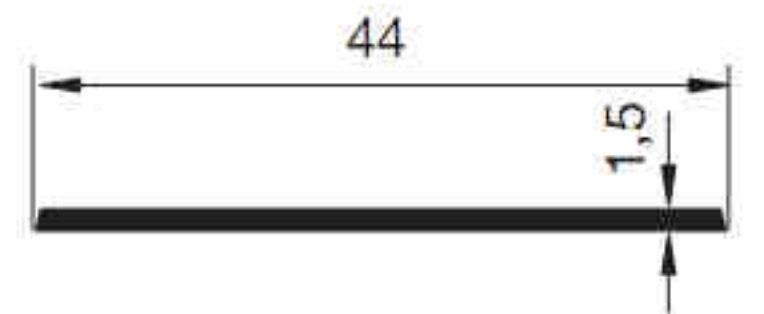

1284 - 0.175 Kg/m

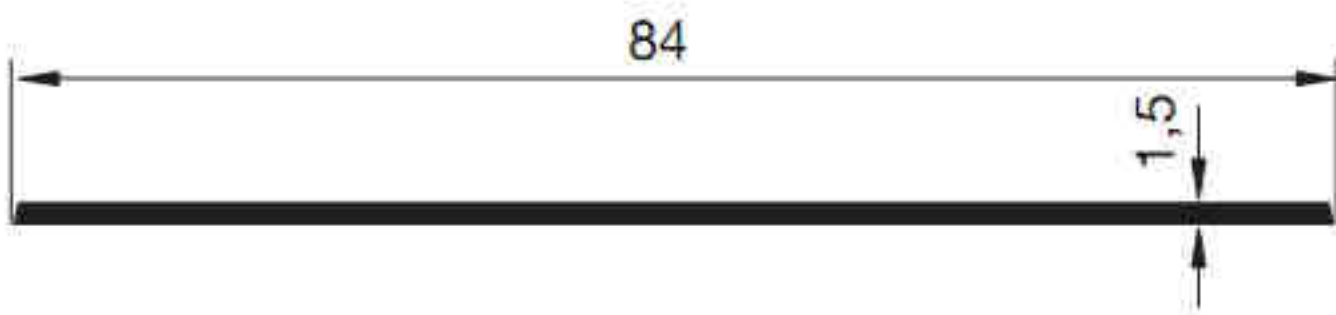

1286 - 0.338 Kg/m

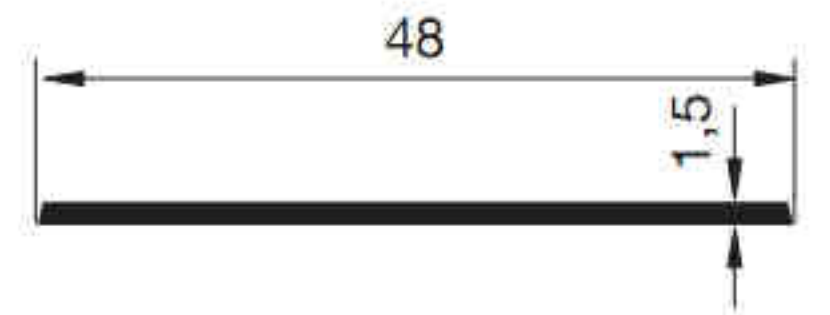

1285 - 0.192 Kg/m

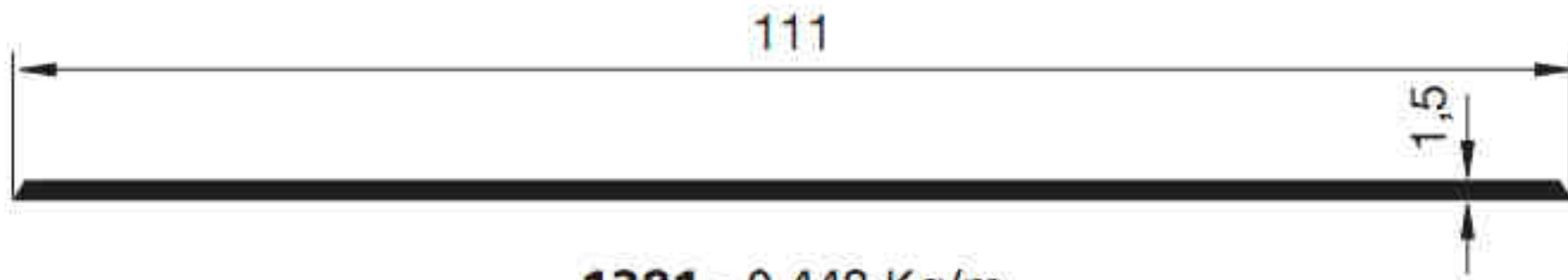

1281 - 0.448 Kg/m

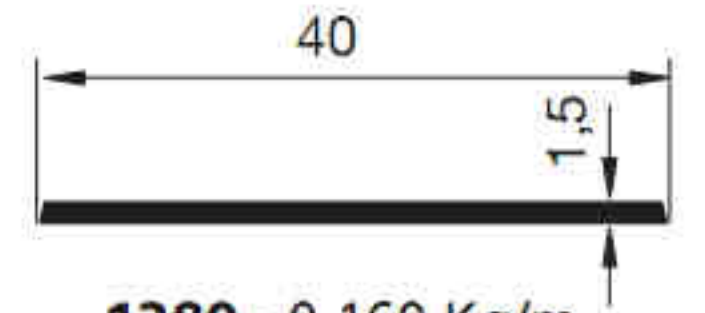

1280 - 0.160 Kg/m

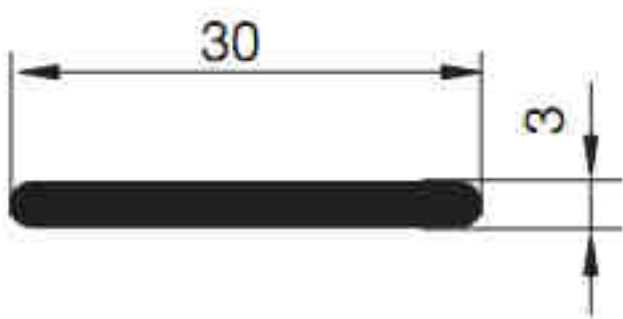

1393 - 0.244 Kg/m

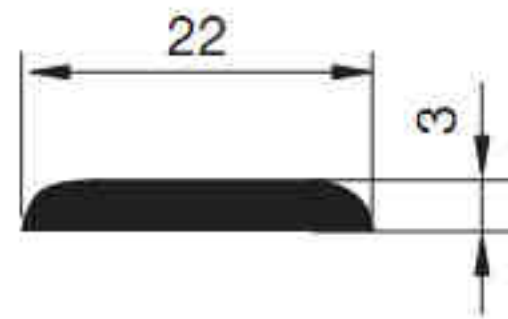

906 - 0.171 Kg/m

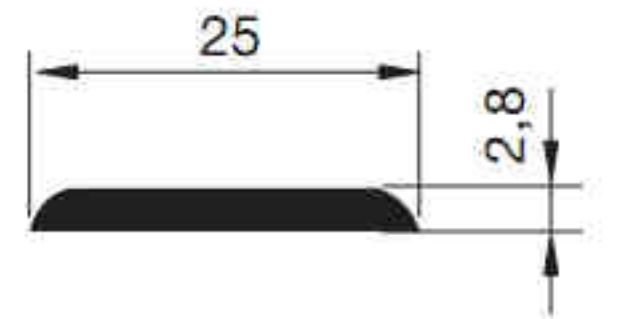

776 - 0.179 Kg/m

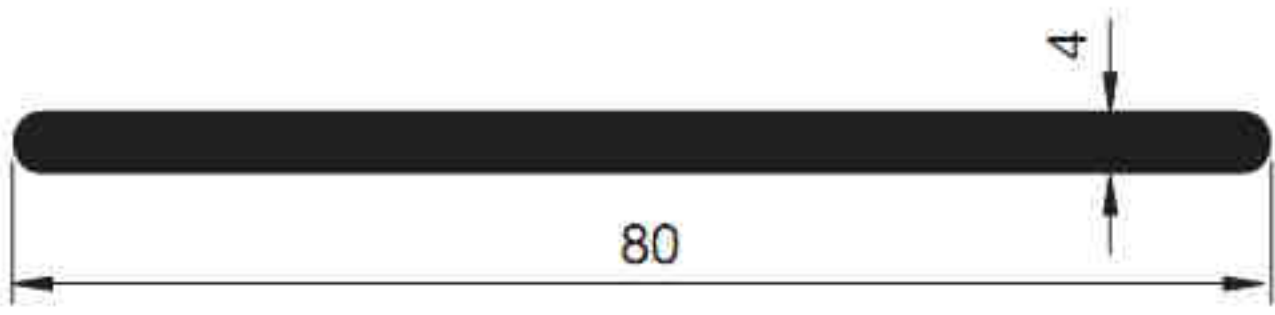

1399 - 0.830 Kg/m

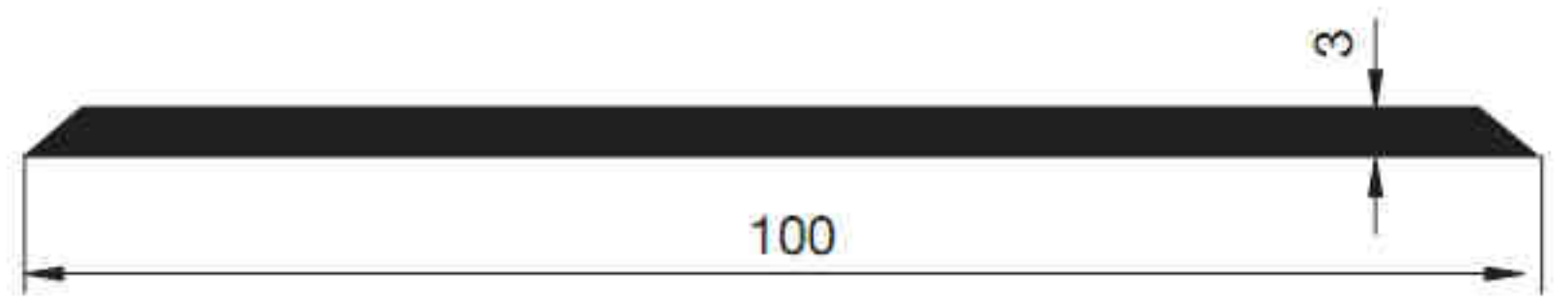

916 - 0.788 Kg/m

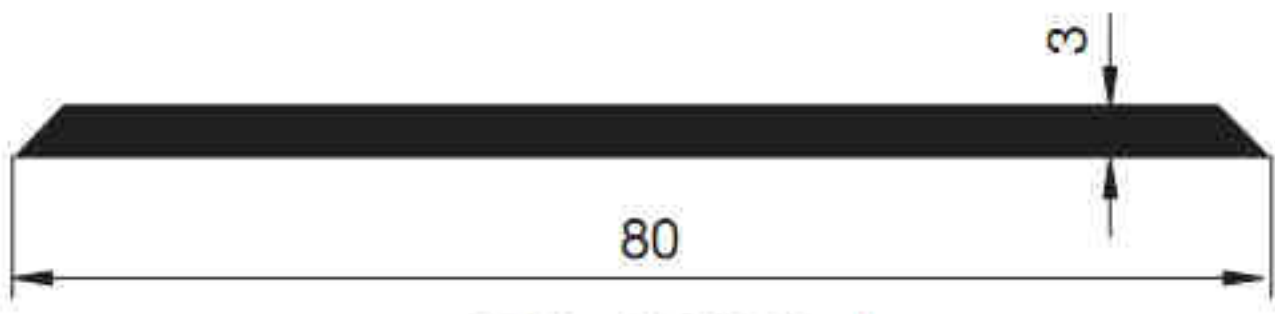

915 - 0.626 Kg/m

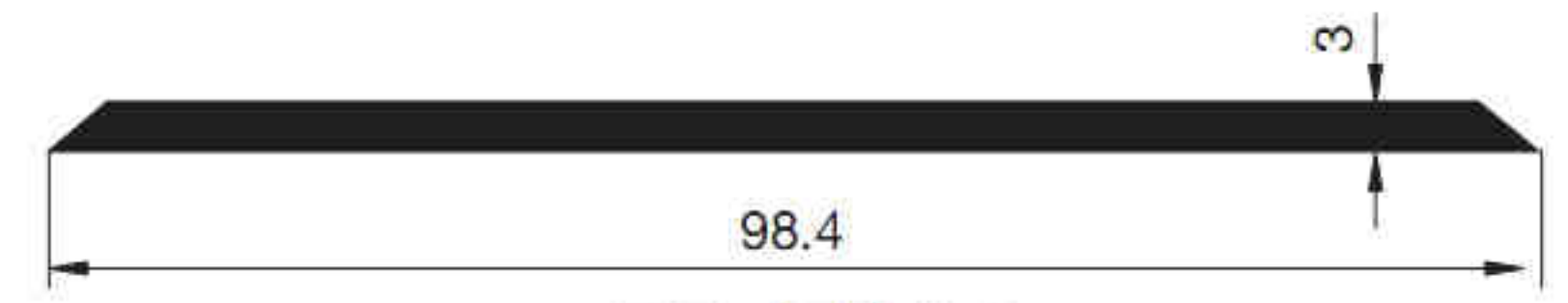

775 - 0.772 Kg/m



8